

M series LED controller M3/M6/M7



M series LED controller is compatible with 8 kinds remotes of different function (patent technology) . which means using one receiver could experience single color/CT dimming, RGB/RGBW adjustment to meet customers' different lighting requirements. With the RF remote, speed/brightness adjustment, customise color and lighting changing modes selection could all be achieved

1. Parameter:

Remote(RGB):

- Model: M3/M6/M7
- Remote Distance: 40~50m
- Working Voltage: DC3V(battery CR2032)
- Working Temp.: -20°C~55°C
- Working Frequency: 433.92MHz
- Weight(N.W.): 42g

CV Receiver (RGB CT):

- Model: M4-5A
- Input Voltage: DC5V~DC24V
- Max Current Load: 6A×3CH Max 18A
- Max Output Power: 90W/216W/432W(5V/12V/24V)
- Gray Scale Level: Max 4096×4096×4096
- Working Temp.: -30°C~55°C
- Weight(N.W.): 125g

CC Receiver (RGB CT):

- Model: M4-CC
- Input Voltage: DC12V~DC48V
- Output Voltage: DC3V~46V
- Load Current: CC350mA/700mA/1050mA×4CH
- Output power: 1.05W~48.3W×4CH Max 144.9W
- Gray Scale Level: Max 4096×4096×4096
- Working Temp.: -30°C~55°C
- Weight(N.W.): 125g

2. Product Size:

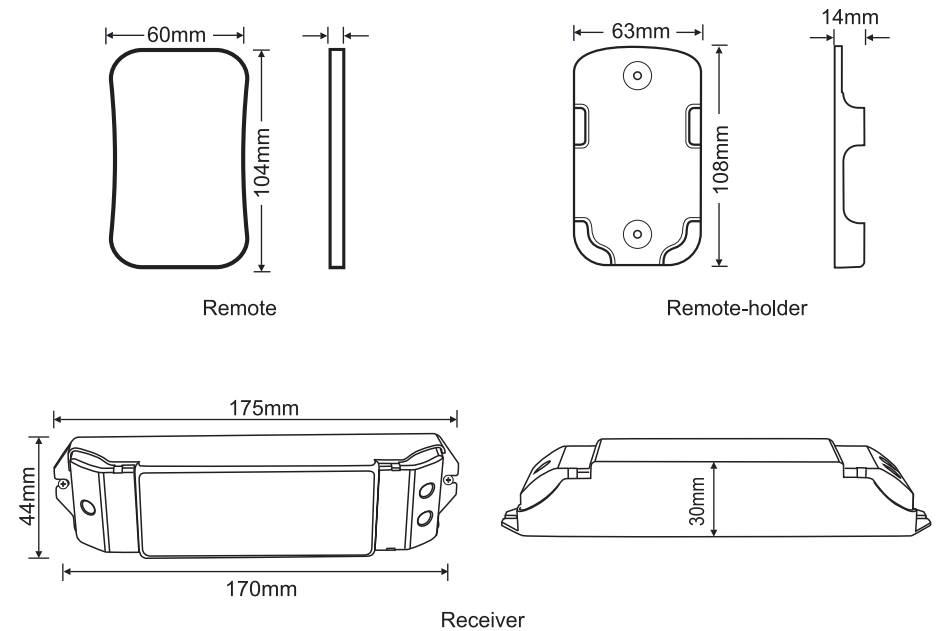

3. The Learning ID Method of Remote Control:

Remote control has been matched with the receiver before leaving factory, if deleted accidentally, you can learn ID as follow.

Learning ID: Short press ID learning button on the M4-5A/M4-CC receiver, the running light is on, then press any key on the M3/M6/M7 remote control, the running light flashes several times, activated.

Cancel ID: Long press ID learning button on the M4-5A/M4-CC receiver for 5 seconds.

Attn: One receiver can be matched with max 10 same or different kinds remote control.

4. Operating Instruction for Receiver :

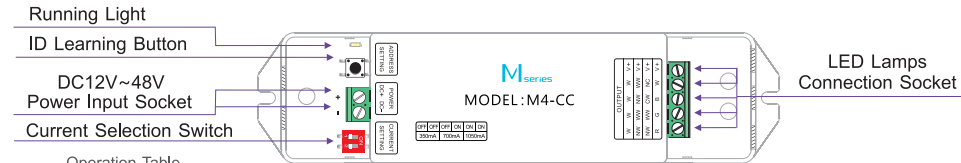

Operation Table

OFF	OFF	OFF	ON	ON	ON
350mA	700mA	1050mA			

5. Operating Instruction for Remote Control :

Sleep Mode: the M3 remote goes on a standby mode to save power when not in use for 30s. press any key to continue.

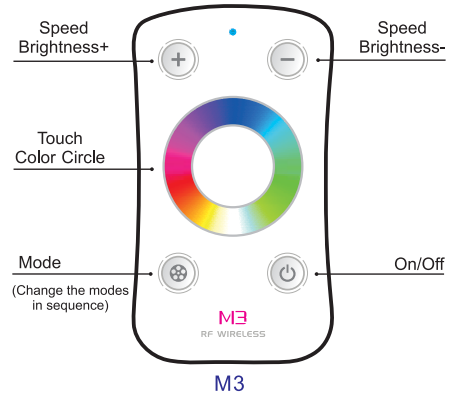

M3 Changing Mode Table

No.	Mode	No.	Mode
1	Static Red	7	Static White
2	Static Green	8	RGB Skipping
3	Static Blue	9	7 Colors Skipping
4	Static Yellow	10	RGB Color Smooth
5	Static Purple	11	Full-color Smooth
6	Static Cyan		

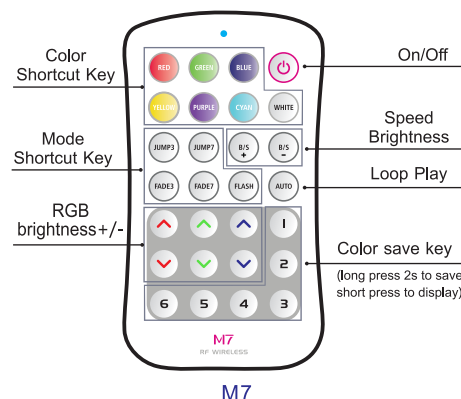
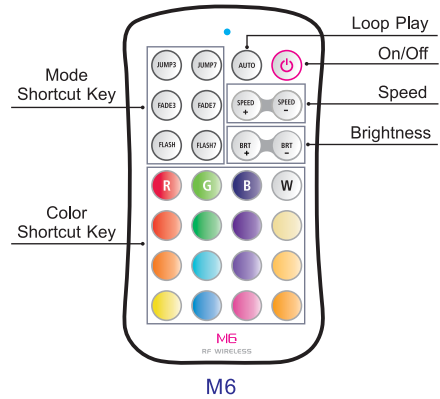

6. Wiring Diagram:

A. CV Receiver

E.g. 1: Connected 12V lamp, loads1~216W (6A×3CH×12V).
[Attn]: RGB strip only use 3 channels, each channel max loads 6A.

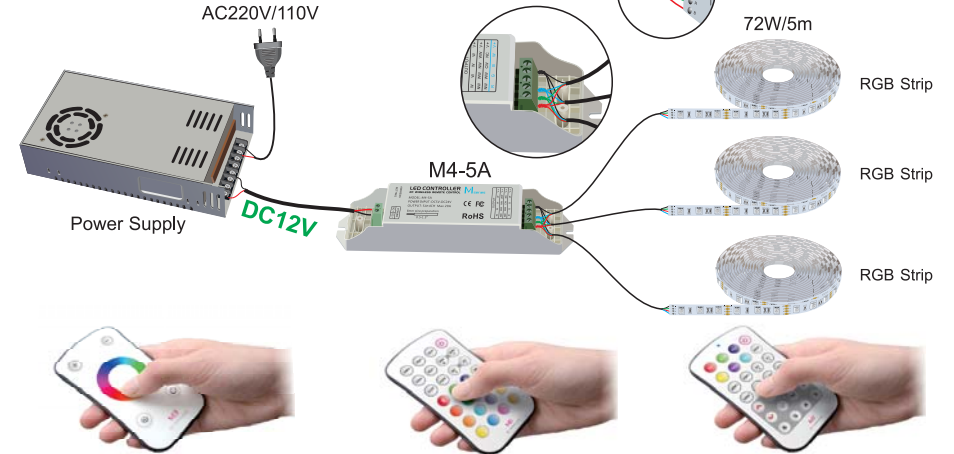

E.g. 2: Connected 24V lamp, loads1~432W (6A×3CH×24V).
[Attn]: RGB strip only use 3 channels, each channel max loads 6A.

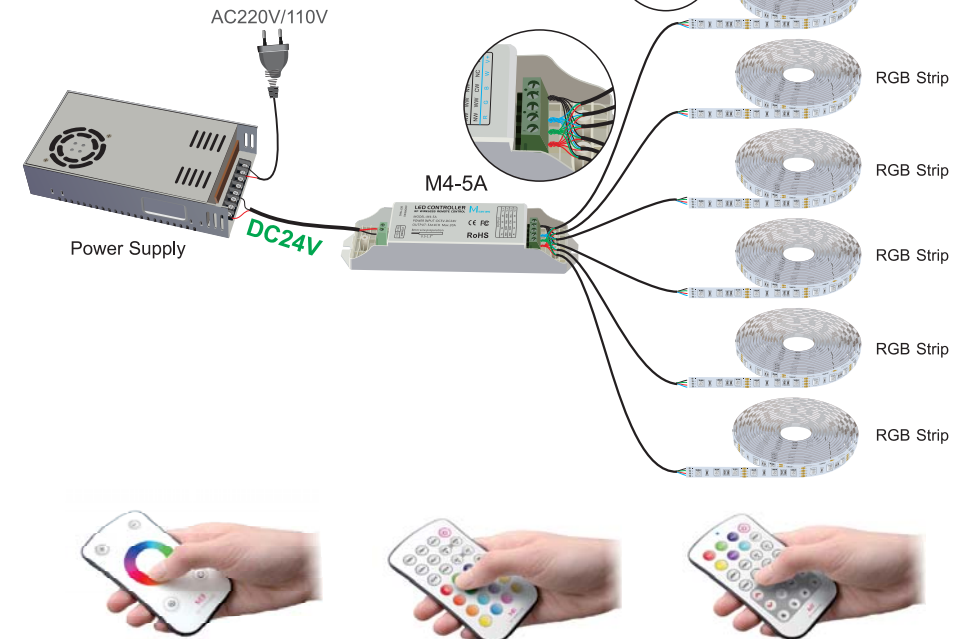

B. CC Receiver

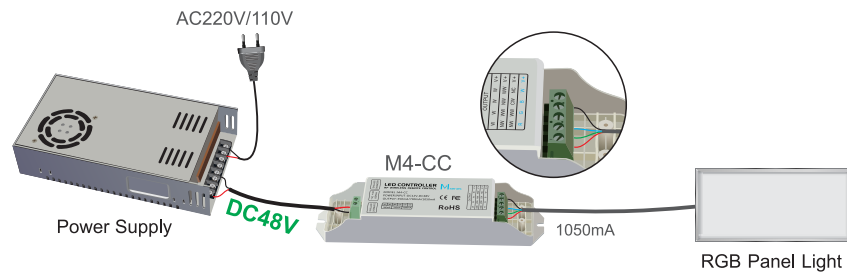
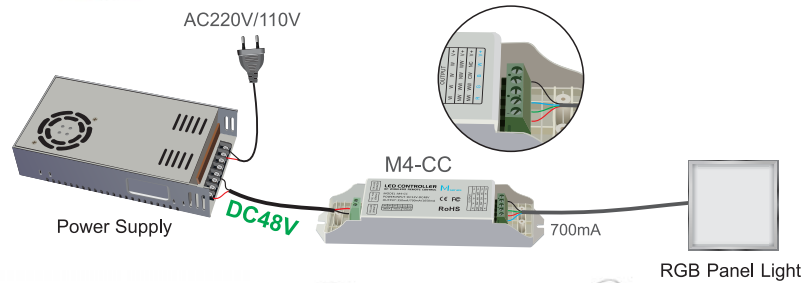
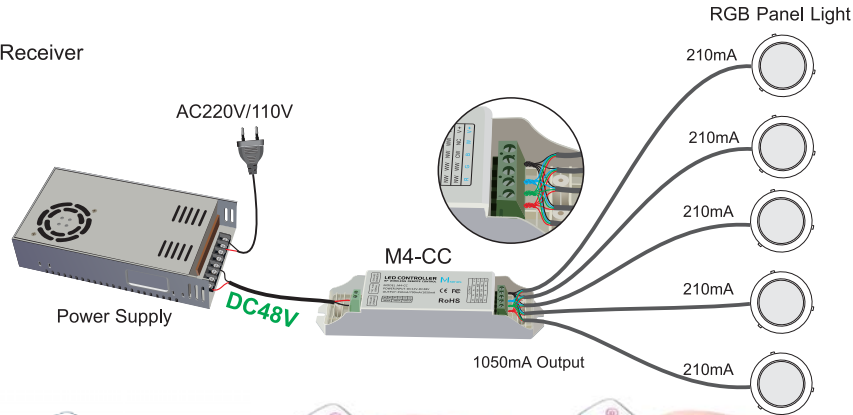

7. Attention:

- 7.1 The product shall be installed and serviced by a qualified person.
- 7.2 This product is non-waterproof. Please avoid the sun and rain. When installed outdoors please ensure it is mounted in a water proof enclosure.
- 7.3 Good heat dissipation will prolong the working life of the controller. Please ensure good ventilation.
- 7.4 Please check if the output voltage of any LED power supplies used comply with the working voltage of the product.
- 7.5 Please ensure that adequate sized cable is used from the controller to the LED lights to carry the current. Please also ensure that the cable is secured tightly in the connector.
- 7.6 Ensure all wire connections and polarities are correct before applying power to avoid any damages to the LED lights.
- 7.7 If a fault occurs please return the product to your supplier. Do not attempt to fix this product by yourself.

8. Warranty Agreement:

- 8.1 We provide lifelong technical assistance with this product:
 - A 5-year warranty is given from the date of purchase. The warranty is for free repair or replacement and covers manufacturing faults only.
 - For faults beyond the 5-year warranty we reserve the right to charge for time and parts.
 - 8.2 Warranty exclusions below:
 - Any man-made damages caused from improper operation, or connecting to excess voltage and overloading.
 - The product appears to have excessive physical damage.
 - Damage due to natural disasters and force majeure.
 - Warranty label, fragile label and unique barcode label have been damaged.
 - The product has been replaced by a brand new product.
 - 8.3 Repair or replacement as provided under this warranty is the exclusive remedy to the customer. LTECH shall not be liable for any incidental or consequential damages for breach of any stipulation in this warranty.
 - 8.4 Any amendment or adjustment to this warranty must be approved in writing by LTECH only.
- ★ This manual only applies to this model. LTECH reserves the right to make changes without prior notice.